

# RODLESS CYLINDER WITH BALL RECIRCULATING GUIDE Ø 16, 25, 32, 40, 63

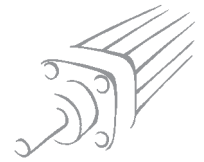

1

The range of rodless cylinders with ball circulation guides is available with five different bores Ø 16, 25, 32, 40 and 63.

The bore 63 can be supplied in two versions: the "standard" one for intermediate loads and the "heavy" one for considerably weighty loads. Besides the general features specified for standard rodless cylinders, the other main features are:

- Very high load capacity, acting in all directions without discharging onto the cylinder slide.
- Hardened steel guide connected firmly to the cylinder jacket.
- Ball circulation shoes constructed using special technology that make them very silent when the guide slides, with very long maintenance intervals. For example, they only need lubricating every 2000 km or once a year.
- Extra sturdy slide support with various holes for fixing the loads. Holes for centring pins are also provided.
- 100 to 2650 stroke at intervals of 1 mm.
- Integrated pneumatic adjustable cushioning.
- Adjustable limit switches and decelerations can be applied at any time.

For this type of cylinder (size 32 and upwards), the valves can be fitted directly using the retracting sensors without requiring any intermediate brackets.

Refer to the table on page 1.1/97.

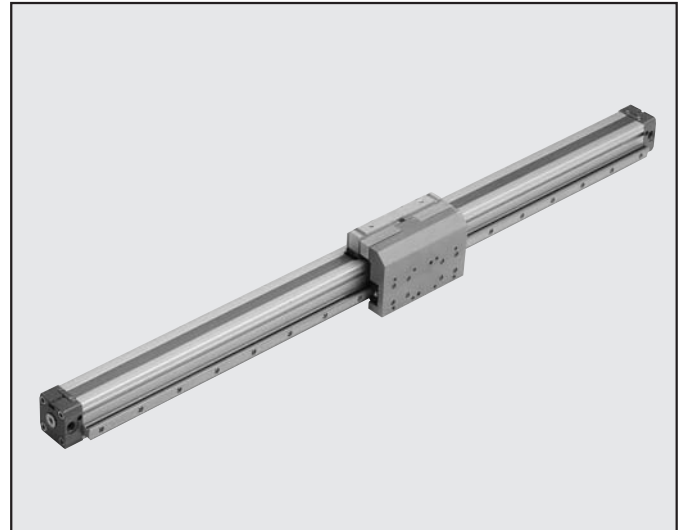

TECHNICAL DATA		NBR	FKM/FPM
Operating pressure	bar	0.5÷8	
	MPa	0.05÷0.8	
Temperature range	psi	7÷116	
	°C	-15÷80	
	°F	- 5÷176	
Fluid	50µm unlubricated filtered air lubrication, if used, must be continuous		
Bores	Ø 16, 25, 32, 40 and 63		
Type of construction	Doubl-acting rodless cylinder with direct transmission system		
Strokes	Ø 16: 100 to 1350 with 1 mm interval		
	Ø 25: 100 to 2300 with 1 mm interval		
	Ø 32: 100 to 2300 with 1 mm interval		
	Ø 40: 100 to 2250 with 1 mm interval		
	Ø 63 standard: 100 to 2100 with 1 mm interval		
	Ø 63 heavy: 100 to 2650 with 1 mm interval		
Threaded ports	M5, G1/8", G1/4", G3/8"		
Assembly	as required		
Recommended speed	<1 m/s (NBR)	≥1 m/s (FKM/FPM)	
Weight	See GENERAL TECHNICAL DATA PAGE 1.1/07		
Max. speed with decelerators	<1 m/s (NBR)	2 m/s (FKM/FPMs)	
For no-stick slip versions, use no-lubricated air only			

## COMPONENTS

### For version 275

- ① CYLINDER: see construction details on page 1.1/117
- ② GUIDE: hardened steel
- ③ SHOE: steel with hardened ball circulation
- ④ SLIDE SUPPORT: anodised aluminium

### For version 276

Besides the details specified above:

- ⑤ END-OF-STROKE STUD PIN: zinc-plated steel, complete with 2 zinc-plated nuts for fixing.
- ⑥ DECELERATOR: burnished steel, complete with 2 zinc-plated or burnished nuts for fixing
- ⑦ DECELERATOR SUPPORT: anodised aluminium
- ⑧ BRACKET: hardened-and-tempered and zinc-plated steel

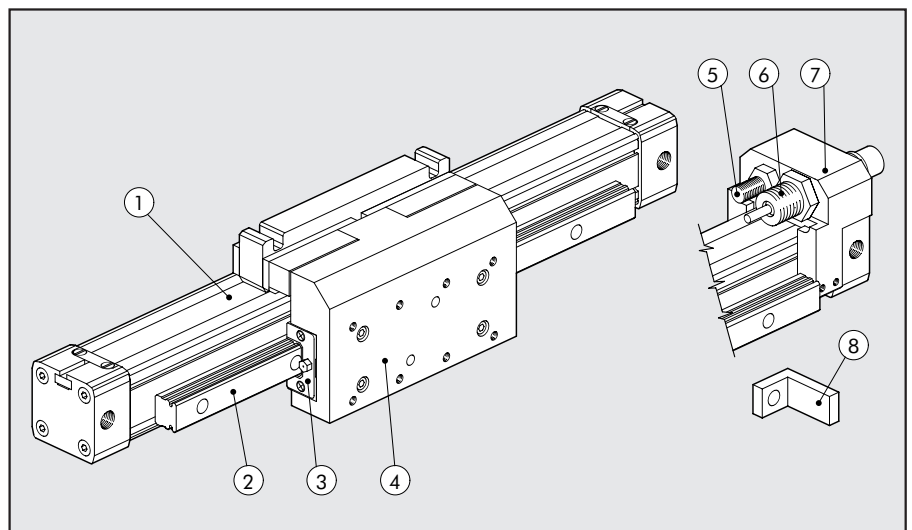

### DIMENSIONES - FORCES AND MOMENTS

Ø	Version	Actual force F at 6 bar [N]	Cushioning stroke [mm]	K [mm]	X [mm]	Y [mm]	Z [mm]	Max load L [N]	Max load G [N]	Ma max. [Nm]	Mr max. [Nm]	Mv max [Nm]
16	-	110	15	35	16	29	33	500	500	16	15	16
25	-	250	21	50.5	21	44	51.5	1500	1500	100	50	100
32	-	420	26	59	22.5	53.5	70	3000	3000	200	100	200
40	-	640	32	68	24.7	58	73	4000	4000	200	140	200
63	standard	1550	40	84	23.1	79	100	6000	6000	400	140	400
63	heavy	1550	40	91	29.2	79	88	10000	10000	600	400	600

N.B.: when the cylinder is subjected simultaneously to torque and force, it is advisable to keep to the following equations

$$Ma = F x (hr + Y) \quad Mr = G x (hr + z) + Lx (hv + X) \quad Mv = F x (K + hv)$$

$$\frac{Ma}{Ma_{max}} + \frac{Mr}{Mr_{max}} + \frac{Mv}{Mv_{max}} + \frac{L}{L_{max}} + \frac{G}{G_{max}} \leq 1$$

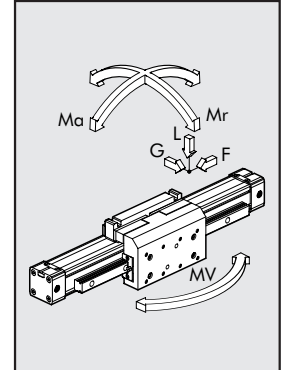
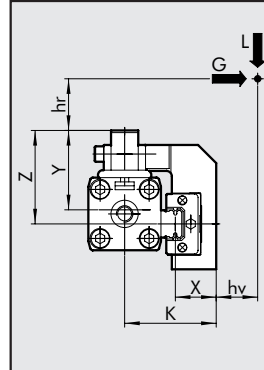

### DIAGRAM OF SPEED AND MAXIMUM CUSHIONABLE LOAD

For the cylinder to reach the end-of-stroke position without intense or repeated impact which would damage it, it is necessary to annul the kinetic energy of the moving mass and the work generated. The maximum cushionable load depends on the traversing speed and the absorption of the air buffer supplied standard with the various cylinders. The diagram shows the speeds and cushionable mass for the various diameters at a pressure of 6 bar.

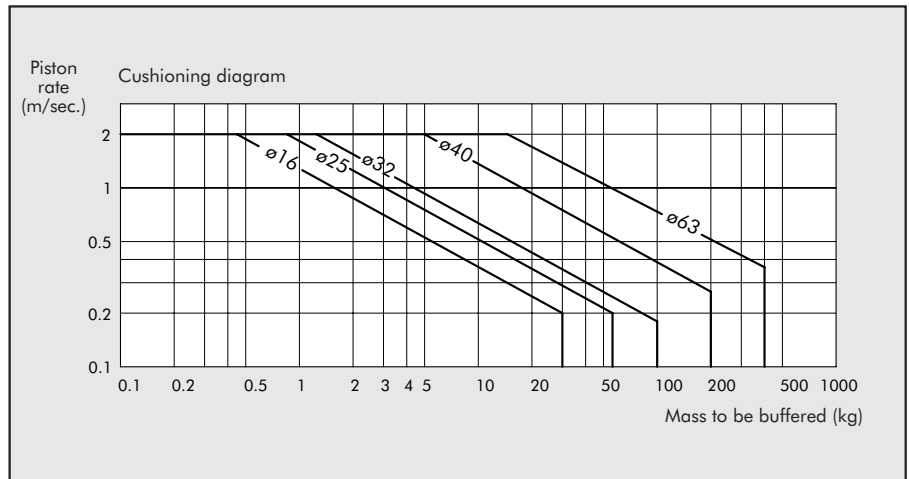

### MAXIMUM LOAD ACCORDING TO THE DISTANCE BETWEEN SUPPORTS

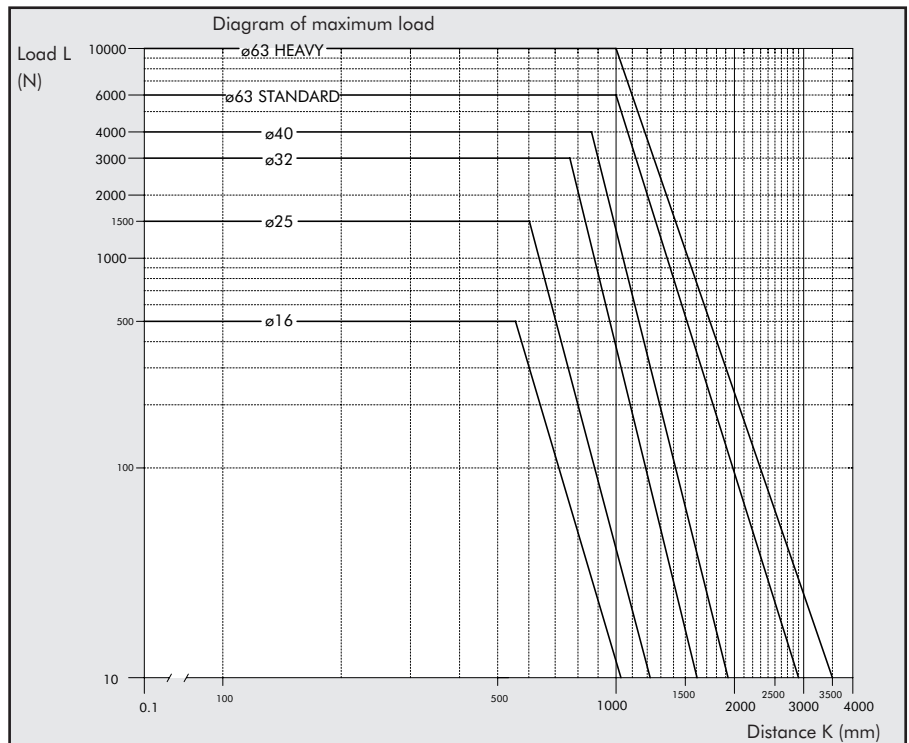
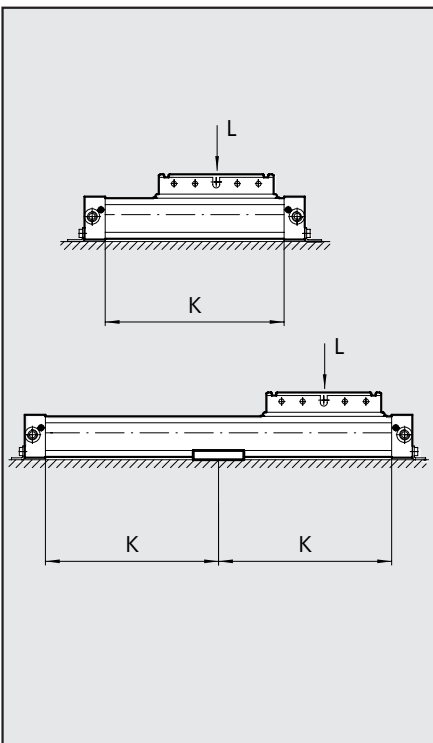



RODLESS CYLINDER WITH BALL RECIRCULATING GUIDE Ø 16

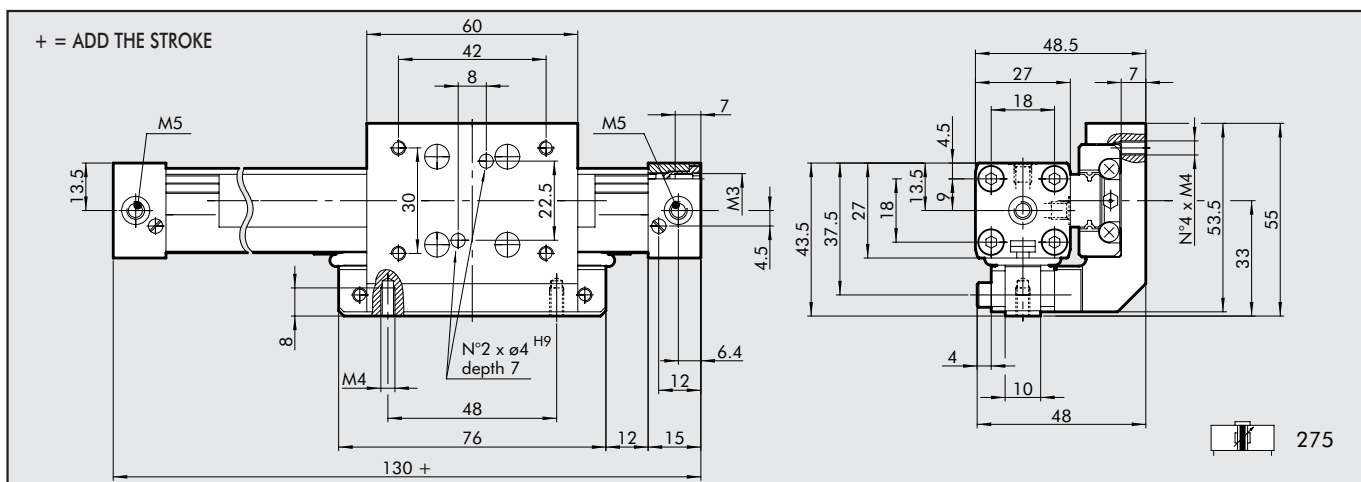

RODLESS CYLINDER WITH BALL RECIRCULATING GUIDE Ø 25

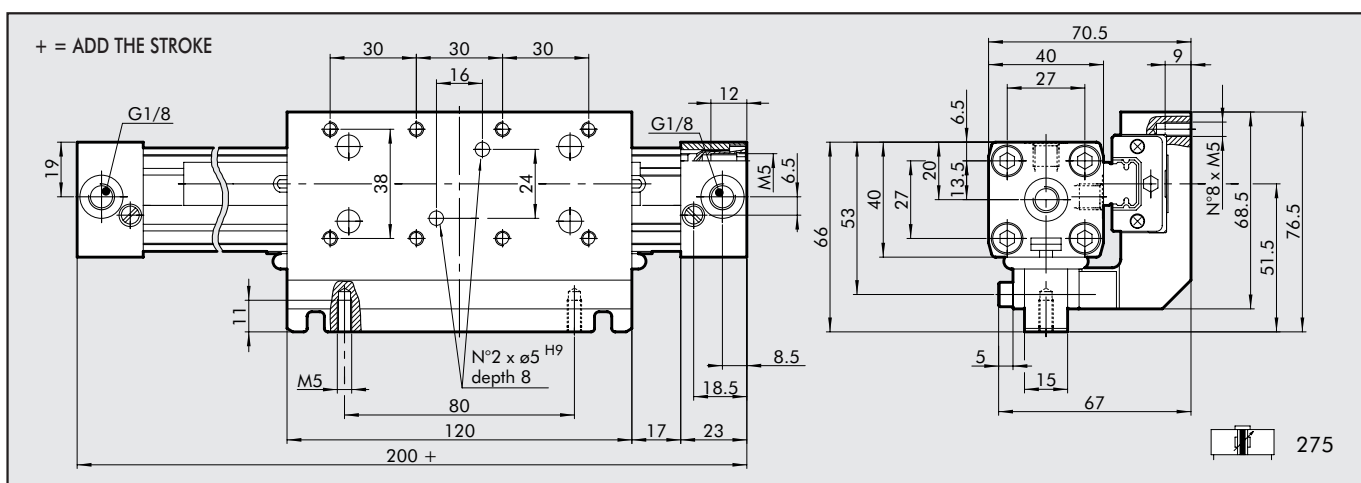

RODLESS CYLINDER WITH BALL RECIRCULATING GUIDE Ø 32; Ø 40

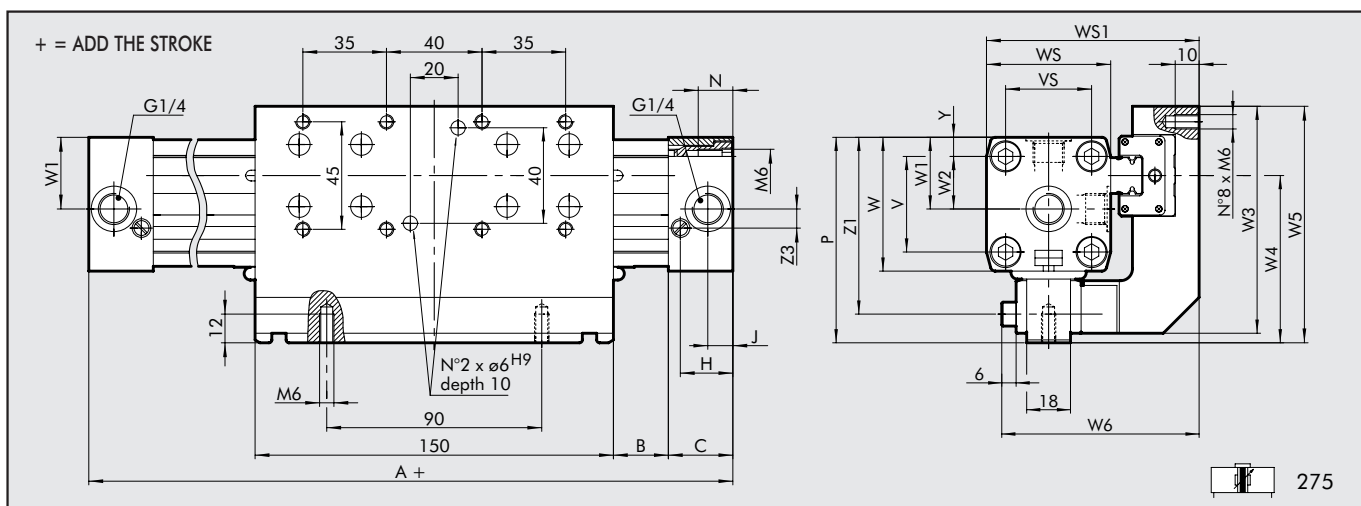

Ø	A	B	C	H	J	N	P	V	VS	W	WS	WS1	W1	W2	W3	W4	W5	W6	Y	Z1	Z3
32	250	23	27	22	10.5	14	86	40	36	56	52	85	30	22	95	70	99	78.5	8	74	8
40	300	45	30	24	15	17.5	97	54	54	69	72	104	36	27	98	73	102	88	9	85	11.8

## RODLESS CYLINDER WITH BALL RECIRCULATING GUIDE Ø 63

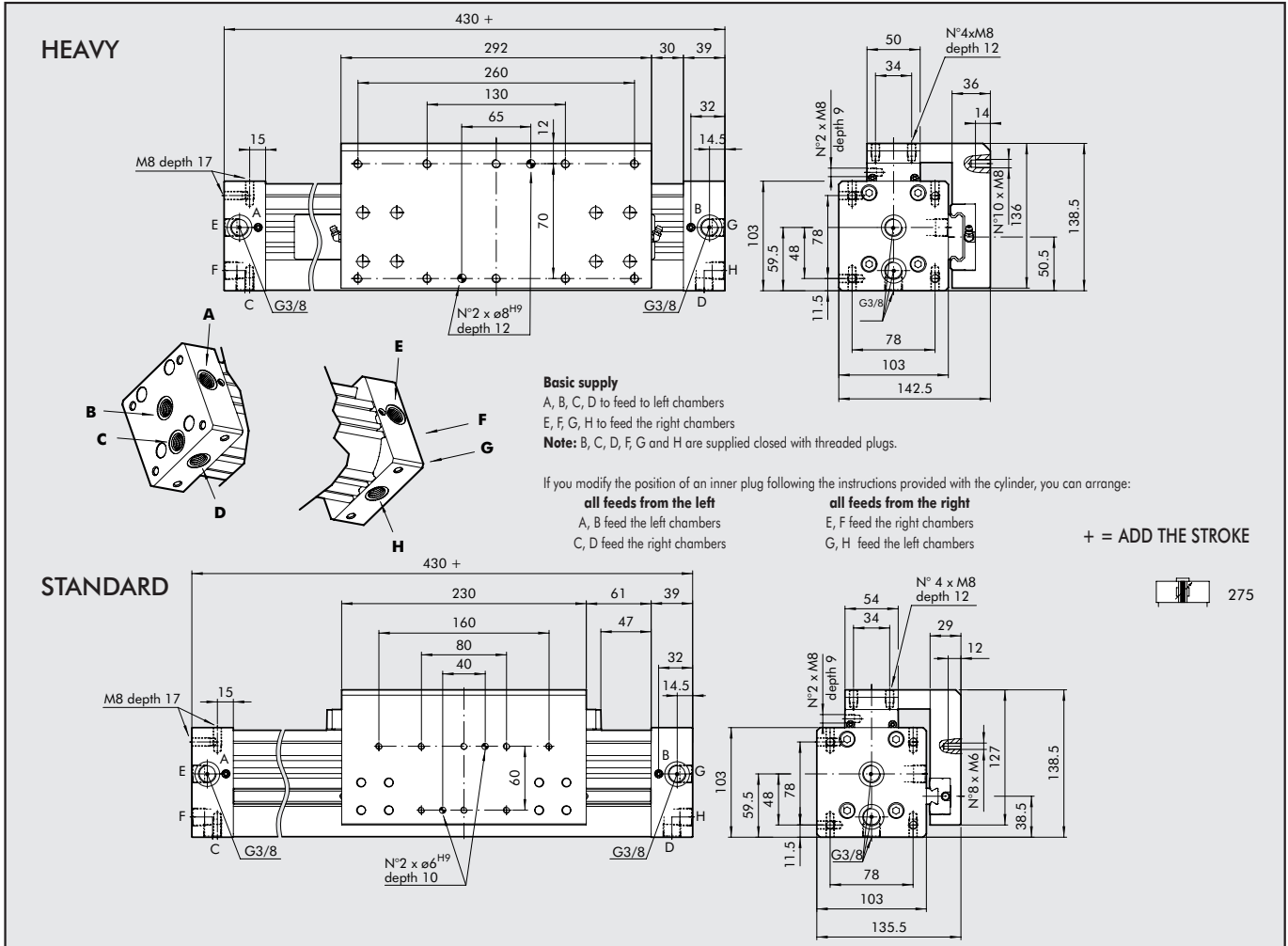

## ASSEMBLY DIAGRAMS

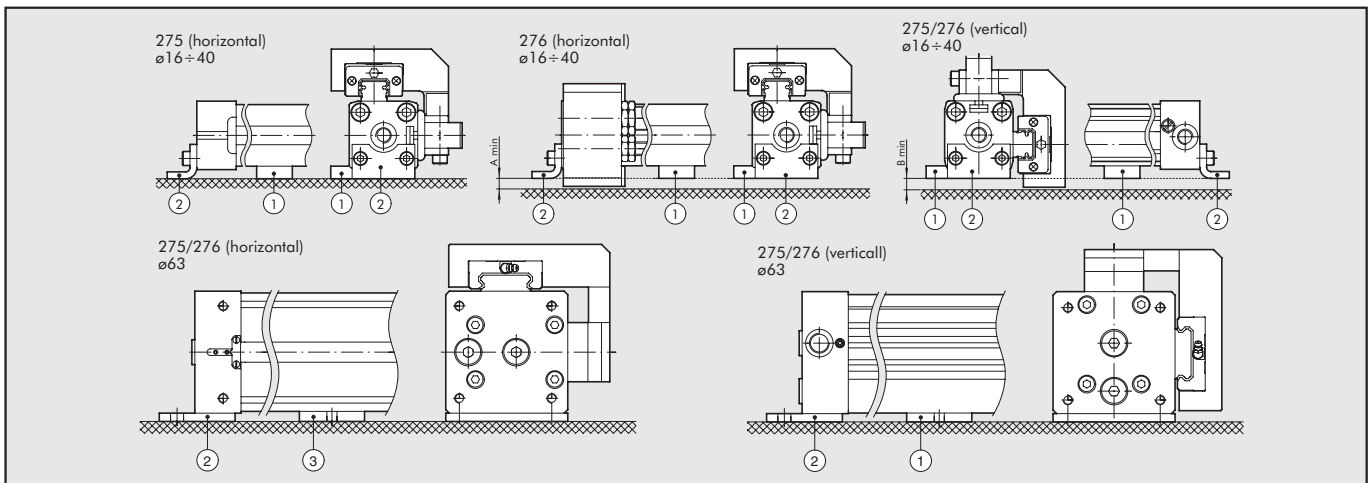

Ø	A min	Horizontal layout		B min	Vertical layout	
		Intern. support code (1)	Leg code (2)		Intern. support code (1)	Leg code (2)
16	8	W0950164004	W0950167001	12	W0950164004	W0950167001
25	10	W0950254004	W0950257001	10	W0950254004	W0950257001
32	4	W0950324004	W0950328035	11	W0950324004	W0950327001
40	3	W0950404004	W0950407001	5	W0950404004	W0950407001
63	-	W0950637032	W0950637001	-	W0950637036	W0950637001



## RODLESS CYLINDER WITH BALL RECIRCULATING GUIDE + SHOCK ABSORBERS Ø 16÷63

1

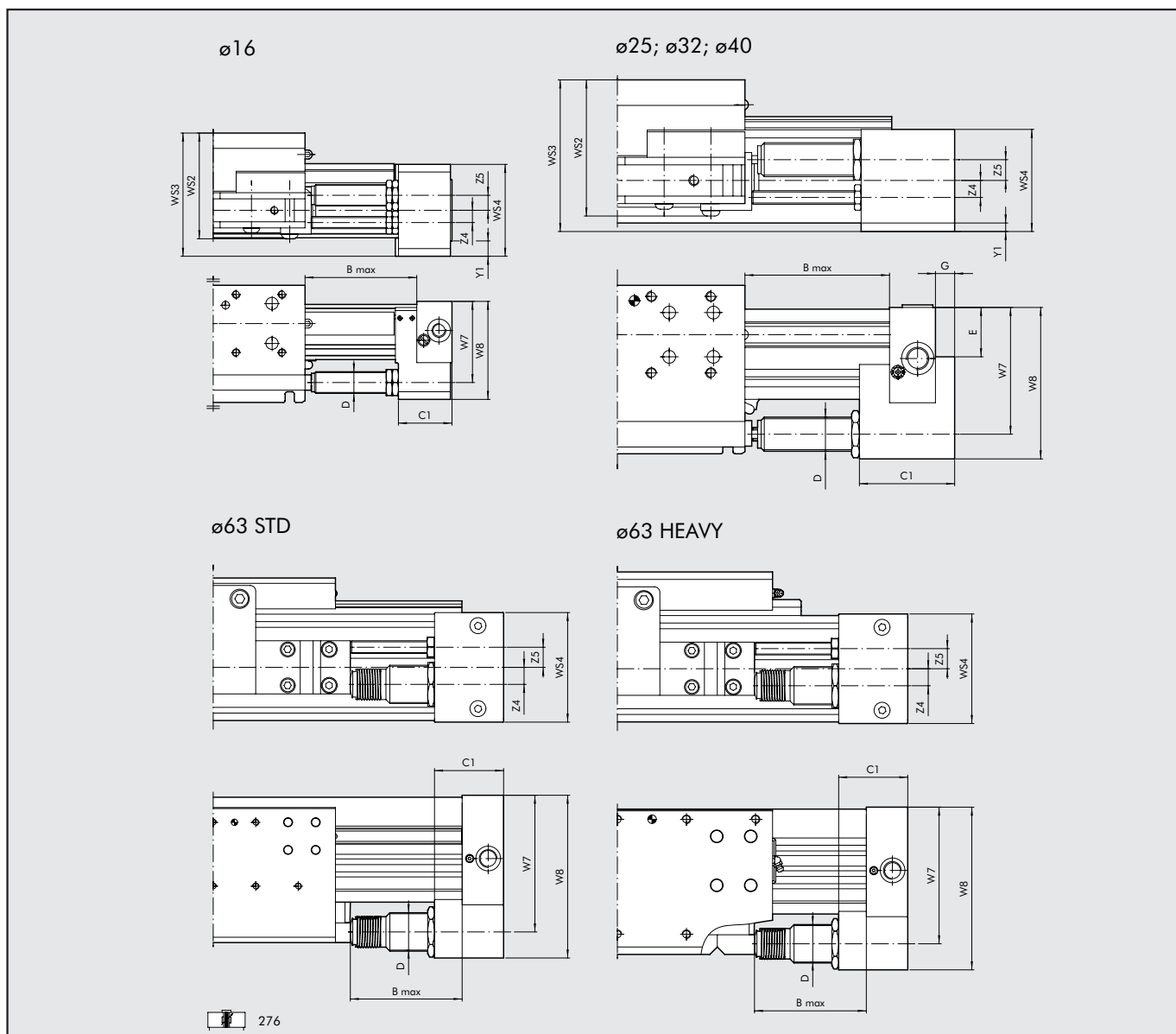

Ø	Version	B max	C1	D	E	G	W7	W8	WS2	WS3	WS4	Y1	Z4	Z5	Stroke	Max. cushioned force		Max. impact force [N]	Max. thrust force [N]
																Per stroke [J]	Per hour [J]		
16	-	50	22	M12x1	-	-	38	46	52	56	42	7.5	7	7.5	10	4.5	14125	1000	220
25	-	72	44	M14x1	17	9	53	67	71	80.5	50	5	8	9.8	16	18	34000	2800	530
32	-	90	56	M20x1.5	29	11	74	89	82.5	91	60	4	10	12.2	22	40	53700	3750	890
40	-	105	74	M25x1.5	32.8	14	89	108	92	108	75	1.5	12.5	12.7	25	65	70000	5500	1550
63	standard	105	65	M36x1.5	-	-	128.5	153	-	-	103	-	16	19	25	125	91000	11120	2220
63	heavy	105	65	M36x1.5	-	-	128.5	153	-	-	103	-	16	19	25	125	91000	11120	2220

For graphs to help choose shock absorbers see page 1.1/124

### KEY TO CODES

CIL	2 7	5	0	2 5	0 0 5 0	C	N
	TYPE		BORE		STROKE	CONFIGURATION	
27	Rodless cylinder	5 6	0 S G A B C	16 25 32 40 63	Ø 16: from 100 to 1350 mm Ø 25-32: from 100 to 2300 mm Ø 40: from 100 to 2250 mm Ø 63 std: from 100 to 2100 mm Ø 63 heavy: from 100 to 2650 mm	N ● V	NBR FKM/FPM
<ul style="list-style-type: none"> <li>■ For speed ≤ 0.2 m/s</li> <li>● For speed ≥ 1 m/s</li> </ul>		<ul style="list-style-type: none"> <li>5 Double-acting cushioned magnetic with ball circulation guides</li> <li>6 Double-acting cushioned magnetic with ball circulation guides + adjustable limit switch and shock absorbers</li> </ul>	<ul style="list-style-type: none"> <li>0 STD Magnetic</li> <li>S STD Non magn.</li> <li>G STD No stick slip</li> <li>A HEAVY Magnetic</li> <li>B HEAVY No stick slip</li> <li>C HEAVY Non magn.</li> </ul>				

## ACCESSORIES

### INTERMEDIATE SUPPORT Ø 16÷25

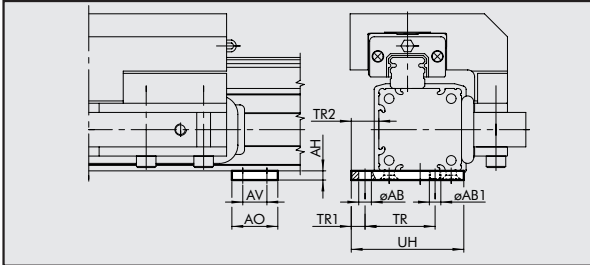

Code	Ø	ØAB	ØAB1	AH	AO	AV	TR	TR1	TR2	UH
------	---	-----	------	----	----	----	----	-----	-----	----

W0950164004	16	3.5	M3	3	12	6	20	4	8	32.5
W0950254004	25	5.5	M5	4	20	10.5	30.5	6	12	49

Note: Supplied complete with 4 screws.

### INTERMEDIATE SUPPORT Ø 32÷40

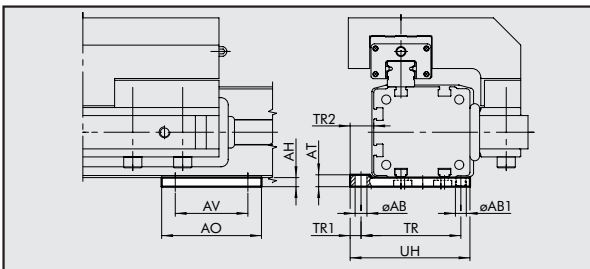

Code	Ø	ØAB	ØAB1	AH	AO	AT	AV	TR	TR1	TR2	UH
------	---	-----	------	----	----	----	----	----	-----	-----	----

W0950324004	32	6.5	M6	5	55	5	40	55	6	13	66
W0950404004	40	6.5	M6	6.6	60	8	45	63	7.5	15	77

Note: Supplied complete with 4 screws, 4 plates.

### INTERMEDIATE SUPPORT KIT Ø 63 FOR HORIZONTAL POSITION

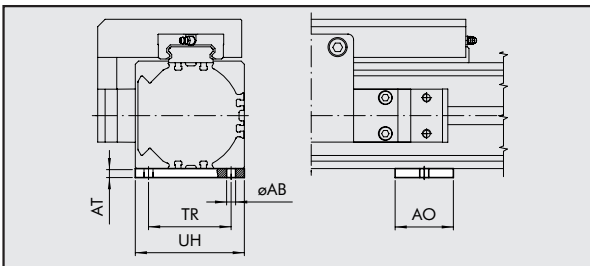

Code	Ø	ØAB	AH	AO	AT	TR	UH
------	---	-----	----	----	----	----	----

W0950637036	63	8.5	7.5	55	8.5	78	103
-------------	----	-----	-----	----	-----	----	-----

Note: Supplied complete with 4 screws, 4 plates.

### INTERMEDIATE SUPPORT KIT Ø 63 FOR VERTICAL POSITION

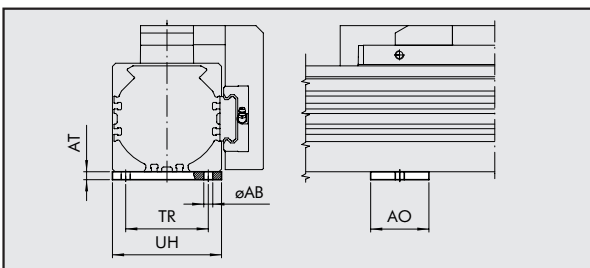

Code	Ø	ØAB	AH	AO	AT	TR	UH
------	---	-----	----	----	----	----	----

W0950637032	63	8.5	7.5	55	7.5	78	103
-------------	----	-----	-----	----	-----	----	-----

Note: Supplied complete with 4 screws, 4 plates.

### SENSOR SUPPORT Ø 16

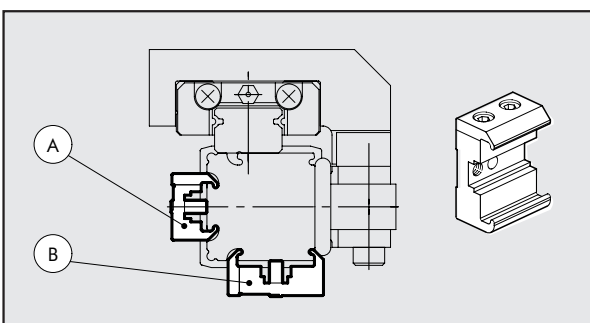

Code	Description	Type	Mounting on the carriage opposite side	Mounting on the guide opposite side
------	-------------	------	--	-------------------------------------

0950164003	sensor support corto	A	•	
0950164001	sensor support std	B		•

Note: Supplied complete with 2 screws, 1 pin.



SENSOR SUPPORT Ø 25		Code	Description	Type	Mounting on the carriage opposite side	Mounting on the guide opposite side
		0950164001	sensor support std	A	•	•
		<p>Note: Supplied complete with 2 screws, 1 pin.</p>				

SLIM SENSOR		Code	Description
	W0952025390	HALL N.O. SENSOR, VERTICAL INSERTION 2.5m	
	W0952029394	HALL N.O. SENSOR, VERTICAL INSERTION 300 mm M8	
	W0952022180	REED N.O. SENSOR, VERTICAL INSERTION 2.5m	
	W0952028184	REED N.O. SENSOR, VERTICAL INSERTION 300 mm M8	
	W0952125556	HALL N.O. SENSOR, VERTICAL INSERTION 2m ATX	
<p>This type of sensor can be inserted in the slot of the sensor from above. This means the cylinder heads do not require a through opening.</p>			
<p>For technical features, refer to page 1.1/98</p>			

BAR FOR GROOVING		Code	Description
	W0950000160	BAR FOR GROOVING L=500 mm	
	<p>Note: the code corresponds to 1 piece</p>		

KIT FOR CYLINDER ASSEMBLY WITH SENSOR SLOTS		Code	Description	Weight [g]
	0950003001	ACC. M3 T-SLOTTED FIXING PLATE	1	
	0950003002	ACC. M4 T-SLOTTED FIXING PLATE	1	
<p>Note: Individually packed</p>				

ADJUSTABLE LIMIT SWITCH AND SHOCK ABSORBERS KIT		Code	Description	Weight [g]
	0950164002	ACC. RODLESS CYLINDER LIMIT SWITCH AND SHOCK ABSORBERS Ø 16	125	
	0950254002	ACC. RODLESS CYLINDER LIMIT SWITCH AND SHOCK ABSORBERS Ø 25	260	
	0950324002	ACC. RODLESS CYLINDER LIMIT SWITCH AND SHOCK ABSORBERS Ø 32	460	
	0950404002	ACC. RODLESS CYLINDER LIMIT SWITCH AND SHOCK ABSORBERS Ø 40	730	
	0950634002	ACC. RODLESS CYLINDER LIMIT SWITCH AND SHOCK ABSORBERS Ø 63	1620	
	<p>Note: Supplied complete with 1 shock absorber support, 1 standard shock absorber, 1 shock absorber nut, 1 limit switch grub screw, 1 grub screw nut ( 2 for ø63 ) , 1 bracket, 1 bracket screw, 4 locking grub screws (for Ø 16 and Ø 25), 4 locking plates and 4 screws (for Ø 32 and Ø 40).</p>			
<p>For graphs to help choose shock absorbers, see page 1.1/124</p>				

SHOCK ABSORBERS		Code	Bore	Description
	0950004003	ø16	Shock absorbers PRO15 MF1 + nut M12x1.5	
	0950004004	ø25	Shock absorbers PRO25 MC2 + nut M14x1.5	
	0950004005	ø32	Shock absorbers PRO50 MC2 + nut M20x1.5	
	0950004006	ø40	Shock absorbers PRO100 MF2 + nut M25x1.5	
	0950004007	ø63	Shock absorbers PRO125 MF3 + nut M36x1.5	

# SPARE PARTS

## "LAST RELEASE" CYLINDER

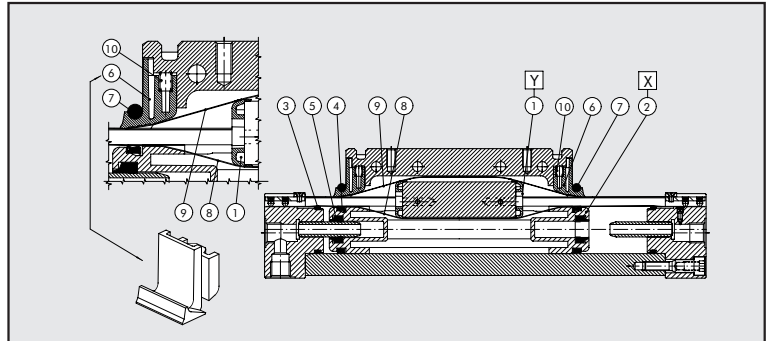
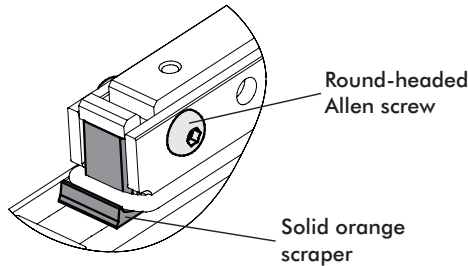

- ① Bands support kit
- ② Piston kit
- ③ ④ ⑤ ⑥ ⑦ ⑩ NBR gaskets Kit (FKM/FPM for ⑦)
- ③ ④ ⑤ ⑥ ⑦ ⑩ FKM/FPM gaskets Kit
- ⑧ ⑨ Bands Kit (inner/outer)

Spare parts label on one cylinder side

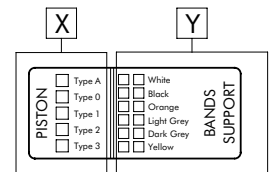

### BANDS SUPPORT KIT POS 1 (Y)

Ø	Code White	Code Black	Code Orange	Code Light grey	Code Dark grey	Code Yellow
16	0090165080	0090165081	0090165082	0090165083	0090165084	0090165085
25	0090255080	0090255081	0090255082	0090255083	0090255084	0090255085
32	0090325080	0090325081	0090325082	0090325083	0090325084	0090325085
40	0090405080	0090405081	0090405082	0090405083	0090405084	0090405085
63	*0090635080	*0090635081	*0090635082	*0090635083	*0090635084	*0090635085

### BANDS KIT (inner and outer) pos 8-9

Ø	Code	
16	0090166...	
25	0090256...	
32	0090326...	
40	0090406...	
63	0090636...	... = STROKE

\* For ø63, the kit includes a strip support and a shim in the colour ordered. Therefore, two kits must be ordered for each cylinder.

### NBR GASKET KIT posn. 3,4,5,6,7,10

Ø	Code
16	0090165022
25	0090255022
32	0090325022
40	0090405022
63	0090635022

### FKM/FPM GASKET KIT posn. 3-4-5-6-7-10

Ø	Code
16	0090165023
25	0090255023
32	0090325023
40	0090405023
63	0090635023

### PISTON KIT POS 2 (X)

Ø	Code				
	Type 0 (0 rings)	Type 1 (1 rings)	Type 2 (2 rings)	Type 3 (3 rings)	Type A (4 rings)
16	0090165015	0090165016	0090165017	0090165018	-
25	0090255015	0090255016	0090255017	0090255018	0090255019
32	0090325015	0090325016	0090325017	0090325018	0090325019
40	0090405015	0090405016	0090405017	0090405018	-
63	0090635015	0090635016	0090635017	0090635018	-

## NOTES

IF THE ENDS OF THE CARRIAGE APPEAR AS BELOW INDICATED, PLEASE CONTACT OUR COMMERCIAL DEPARTMENT FOR THE SPARE PARTS

### "INTERMEDIATE RELEASE"

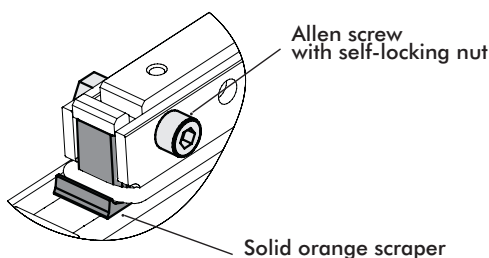

### "OLD RELEASE"

