

bit DEPURATOR

Coalescing mini-depurator

- Space saving
- Minimum load loss as the flow rate varies
- All-round condensate level viewing



TECHNICAL DATA	DEP BIT 1/8"		DEP BIT 1/4"	
	1/8"		1/4"	
Threaded port	1/8"		1/4"	
Degree of filtration	99.97% 0,01 μm			
Max. inlet pressure	MPa	1.3		
	bar	13		
	psi	188		
Maximum suggested flow rate	please look at the flow rate curves at page 3.2/14			
Suggested flow at 6 bar	200 NI/min = 7 scfm			
Fluid	Filtered 5 μm compressed air			
Max temperature at 1 MPa; 10 bar; 145 psi	°C	50		
	°F	122		
Weight	gr	65		
Wall fixing screws	M4			
Mounting position	Vertical			
Condensate drain	Manual/semi-automatic (RMSA) - Automatic (SAC)			
Bowl capacity	cm ³	16		
Notes:	A It is advisable to mount a 5m filter upstream the depurator acting as a rough filter.			

3

USE AND MAINTENANCE

When replacing the coalescing cartridge, unscrew the bowl and then unscrew the screen of the cartridge assembly. Then replace the cartridge. Use a no. 3 compass spanner to unscrew the bowl.

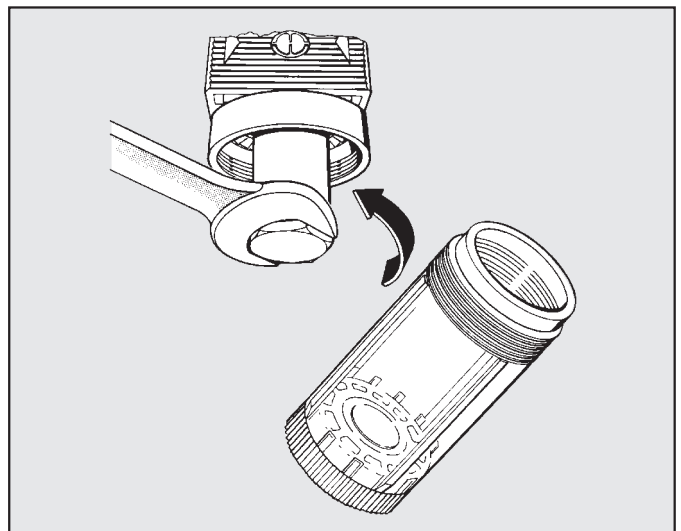

FLOW CHARTS

DEP

$\Delta P = (P_m - P_v)$
psi KPa bar

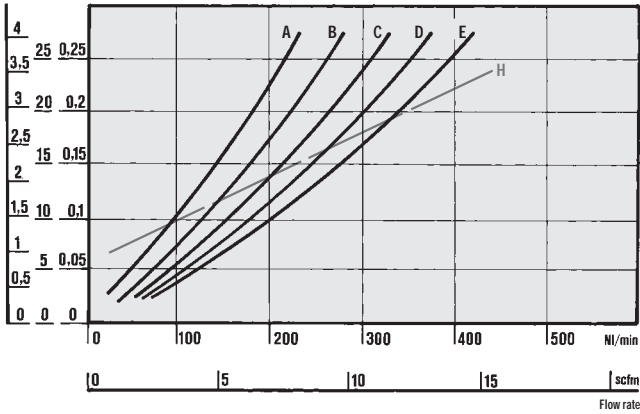

H = Maximum recommended flow for optimal operation

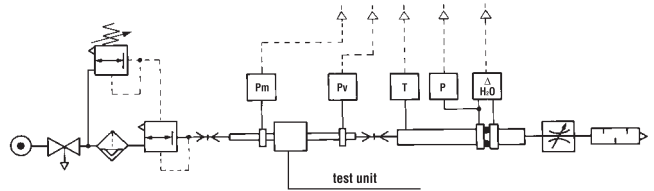

• Flow tests carried out at the Department of Mechanics, Turin Polytechnic, using the computerized test bench following CETOP RP50R recommendations (ISO DIS 6358-2-approved) with ISO 5167 diaphragm gauge.

A = 2 bar - 0,2 MPa - 29 psi
B = 4 bar - 0,4 MPa - 58 psi
C = 6 bar - 0,6 MPa - 87 psi

D = 8 bar - 0,8 MPa - 116 psi
E = 10 bar - 1 MPa - 145 psi

DIMENSIONS

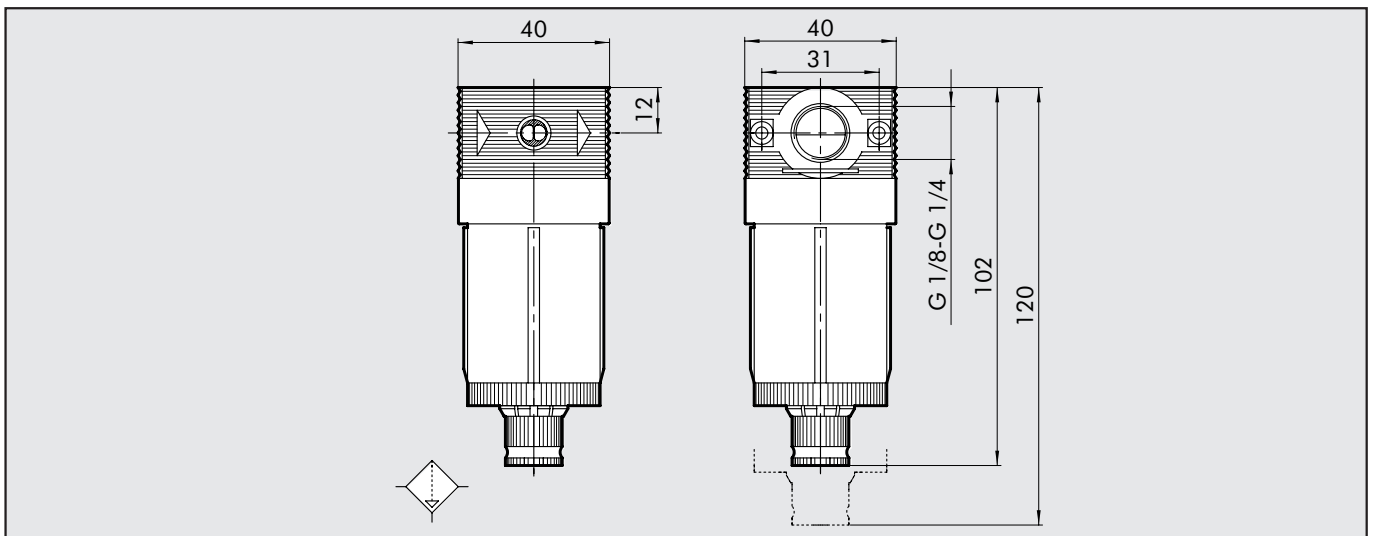

KEY TO CODES

DED	BIT	1/8	RMSA
ELEMENT	SIZE	THREADED PORT	CONDENSATE DRAIN
DED	BIT	1/8 1/4	RMSA

ORDERING CODES

Code	Description
5112001	DEP BIT 1/8 RMSA
5212001	DEP BIT 1/4 RMSA