

PRECISION PRESSURE REGULATOR WITH HIGH EXHAUST FLOW, SERIE GS

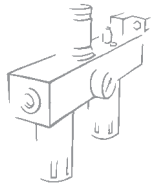

GS is a series of precision regulators, designed for rapid relief of overpressure and a high flow rate.

They feature identical and opposing regulation valves on the inlet and outlet sides. This enables the regulator to behave symmetrically – precise regulation with a high rate of flow both in and out.

The pressure setting is virtually insensitive to changes in the upstream pressure (see diagram below), which guarantees accuracy even when the mains pressure fluctuates considerably.

A slight escape of air is required for correct operation of the regulator – it must not be considered a defect.

The regulator can be fixed using the through holes in the body or a bracket accessory.

The body has a 1/8" pressure gauge fitting.

GS regulators are suitable for applications requiring good accuracy in maintaining the pressure and a certain sensitivity in relieving pressure peaks, e.g. to supply low-friction cylinders, reel tensioners and coil winders. Two sizes of compressed air fitting are available: 1/8" and 1/4". Three different setting ranges are available: 0÷2 bar, 0÷4 bar and 0÷8 bar.



TECHNICAL DATA	1/8"	1/4"
Threaded port	1/8" - 1/4"	
Setting range	0÷2 bar - 0÷4 bar - 0÷8 bar	
Max. input pressure	10	
Flow rate at 6.3 bar (0.63 MPa-91 psi) ΔP 0.5 bar (0.05 MPa - 7 psi)	900	1170
Flow rate at 6.3 bar (0.63 MPa-91 psi) ΔP 1 bar (0.1 MPa - 14 psi)	1200	1380
Fluid	Unlubricated filtered air The air must be at least 10 μm pre-filtered	
Max temperature	50	
Mounting position	In any position	
Pressure gauge port	G 1/8"	
Weight	600	
Exhaust flow rate at 4 bar (regulated pressure)		
ΔP 0,1 bar	450	810
ΔP 0,5 bar	900	1190
Variation in regulated pressure (2 bar) with changes in upstream pressure (4-10 bar)	± 20	
Relieving sensitivity	30	
Air consumption – continuous escape	< 0,1	
Notes	The regulator pressure must always be set upwards. For increased sensitivity, use a pressure regulator with a rated pressure as close as possible to the required value. Do not take air from pressure gauge ports.	

COMPONENTS

- ① Spring: stainless steel
- ② Cartridges: nickel-plated brass
- ③ Poppet: nickel-plated brass
- ④ Ring: vulcanized NBR
- ⑤ Control lever: brass
- ⑥ Bodies: painted aluminium
- ⑦ Control diaphragm: oil-proof rubber
- ⑧ Filter: sintered bronze
- ⑨ Throttle cartridge: brass
- ⑩ Ball: stainless steel
- ⑪ Ball valve: brass
- ⑫ Regulation diaphragm: NBR
- ⑬ Ring nut: technopolymer
- ⑭ Adjusting spring: steel
- ⑮ Scroll: brass
- ⑯ Bell: technopolymer
- ⑰ Adjusting screw: brass
- ⑱ Knob: technopolymer

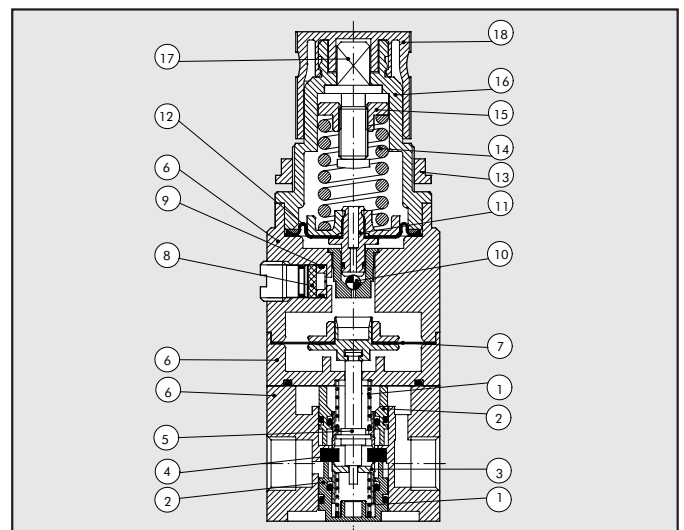

FLOW RATE

Upstream pressure = 10 bar

- P_{reg} = 2 bar
- P_{reg} = 4 bar
- P_{reg} = 6,3 bar

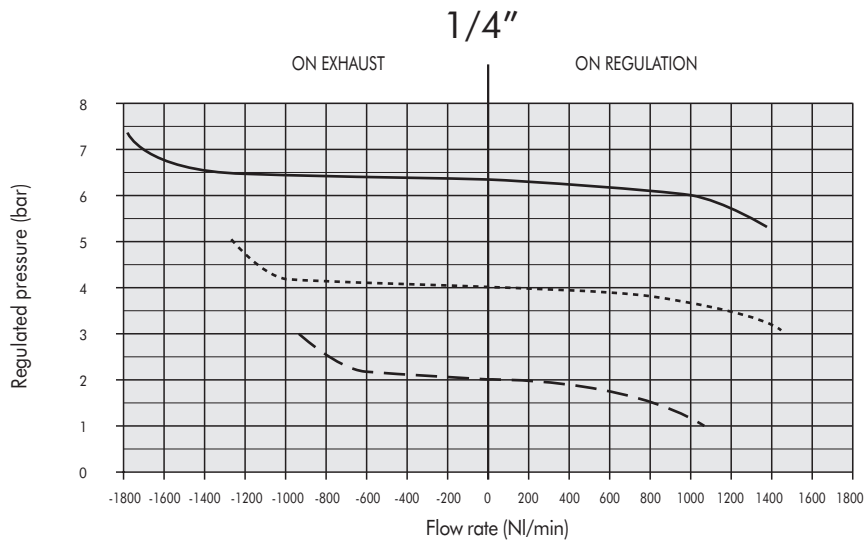
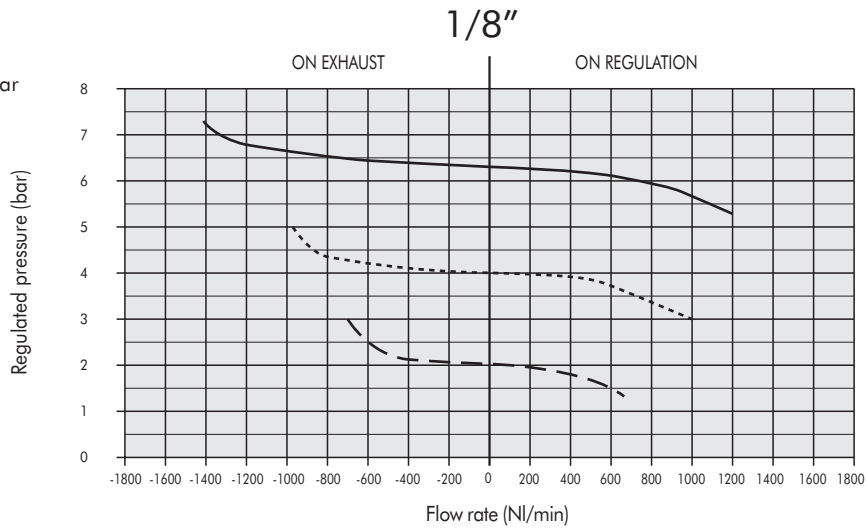

UPSTREAM PRESSURE SENSITIVITY

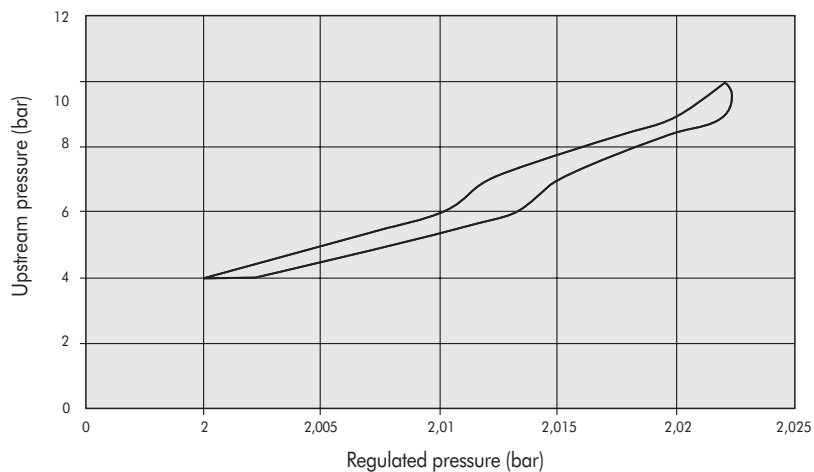

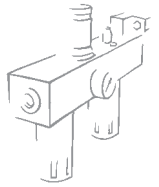

INSTALLATION

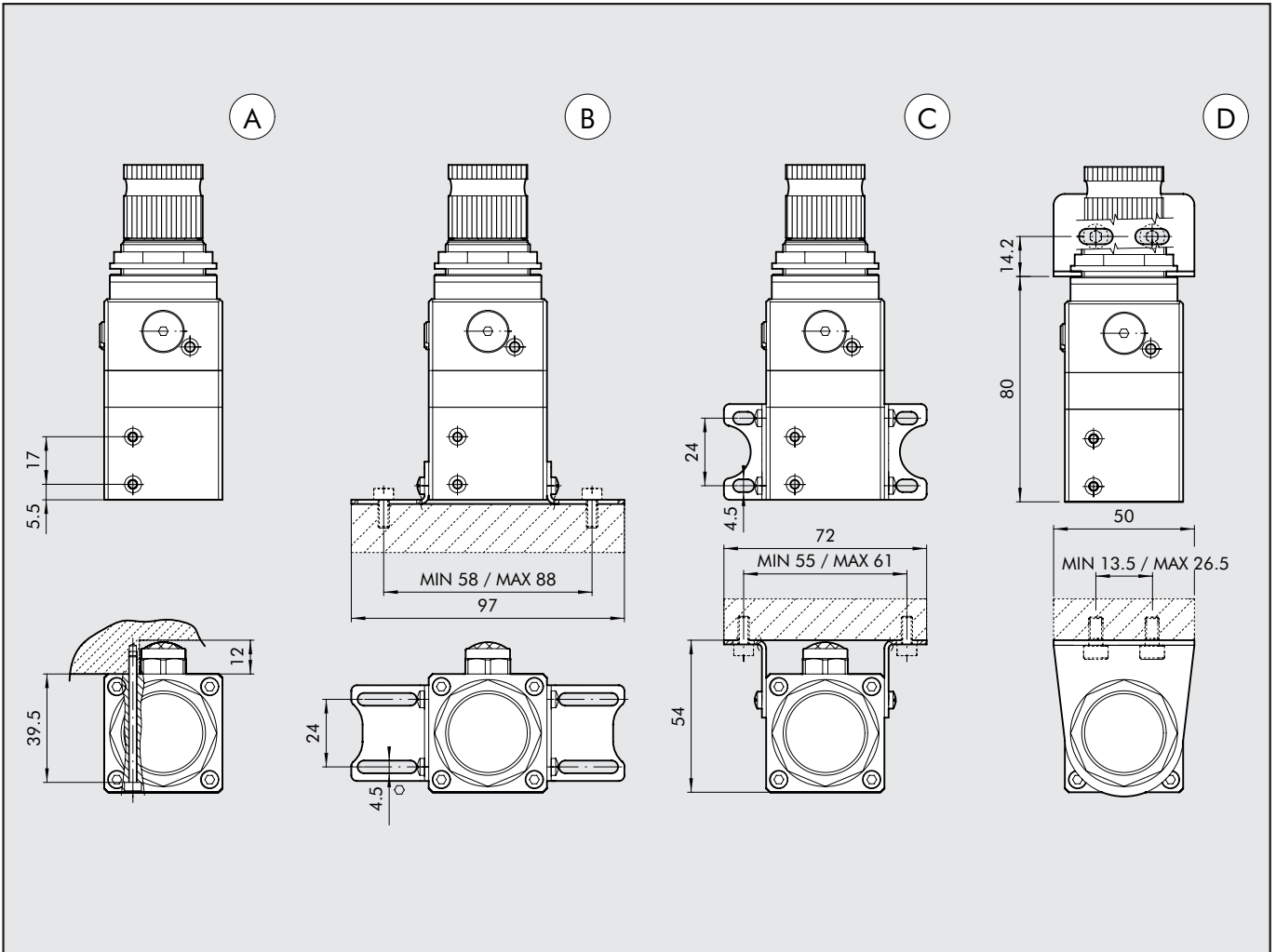

A On the wall with 2 M3 hex screws

B On the base with legs code 9200710

C On the wall with legs code 9200710

D On the wall with bracket code 9200701

DIMENSIONS

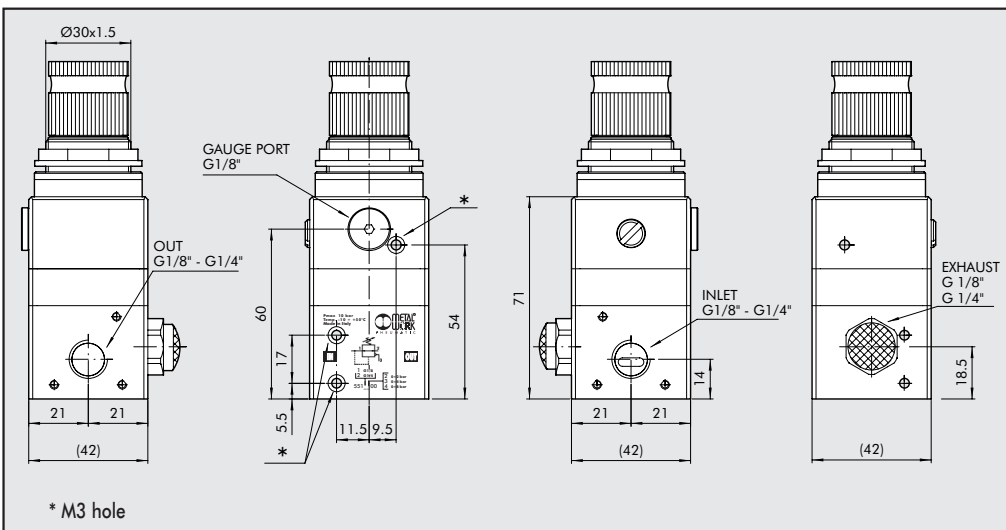

* M3 hole

ORDERING CODES

Code	Description
5511200	REG. GS 1/8 02
5511300	REG. GS 1/8 04
5511400	REG. GS 1/8 08
5512200	REG. GS 1/4 02
5512300	REG. GS 1/4 04
5512400	REG. GS 1/4 08

ACCESSORIES

R/FR FIXING BRACKET

Code Description

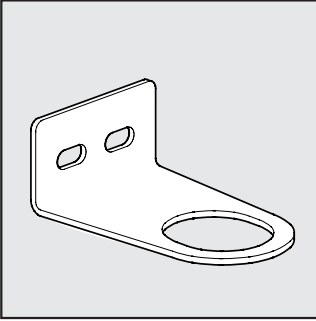

9200701 ACC. SF100 - BIT - ND 1/4

NOTES

FIXING BRACKET KIT

Code Description

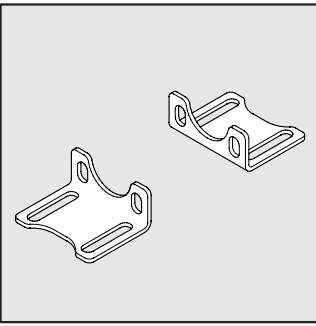

9200710 FIXING BRACKET KIT

N.B. supplied complete with four M4X6 screws

PRESSURE GAUGE

Code Description

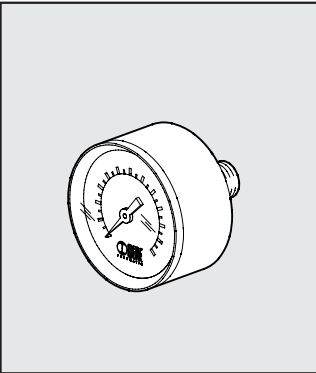

9700102 ACC.M 40 1/8 04
9700101 ACC.M 40 1/8 12

SPARES

UPPER COVER FOR REG GS

Code Description

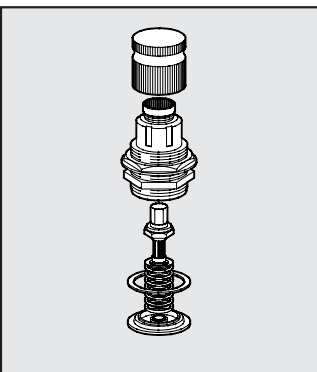

9250835 SPARES CS REG GS 02
9250836 SPARES CS REG GS 04
9250837 SPARES CS REG GS 04